



STITCH



Wireless Smart
DOOR/WINDOW SENSOR

P/N **33048/33049**
User's Manual

CONTENTS

- INTRODUCTION..... 3
- FEATURES..... 3
- CUSTOMER SERVICE..... 3
- PACKAGE CONTENTS 4
- APPLICATIONS..... 4
- PRODUCT OVERVIEW..... 5
- PHYSICAL INSTALLATION..... 5
- APP INSTALLATION AND LOGIN 7
- ADD A DEVICE 8
 - Smart Inclusion Installation 8
 - AP Mode Installation..... 10
- APP FEATURES..... 12
- TECHNICAL SUPPORT 13
- SPECIFICATIONS..... 13
- REGULATORY COMPLIANCE..... 14
 - Notice for FCC 14
 - RF Exposure Statement for FCC..... 14
 - Notice for Industry Canada..... 14
 - Radio Notice for Industry Canada..... 15
 - RF Exposure Statement for Industry Canada 15

INTRODUCTION

This Wireless Smart Door/Window Sensor allows you to remotely monitor your home using your Android™ or iOS® smartphone or tablet. The sensor communicates with your phone through your local Wi-Fi® network, so you won't need any separate mesh network hubs or controllers. Mount it to a door, window, or other entryway to detect when it is opened or closed and receive notification directly to your mobile devices.

FEATURES

- Provides simple 24/7 remote monitoring of your home and entry points
- Set push notifications to your mobile devices and be alerted whenever your window is opened or closed
- Reports battery level and logs events
- Auto-power saving mode enables under normal working conditions
- Built-in tamper switch alerts you when device is tampered with
- Supports scene control and works with other "smart" devices
- Works with other STITCH by Monoprice smart devices (sold separately)

CUSTOMER SERVICE

The Monoprice Customer Service department is dedicated to ensuring that your ordering, purchasing, and delivery experience is second to none. If you have any problem with your order, please give us an opportunity to make it right. You can contact a Monoprice Customer Service representative through the Live Chat link on our website www.monoprice.com during normal business hours (Mon-Fri: 5am-7pm PT, Sat-Sun: 9am-6pm PT) or via email at support@monoprice.com

PACKAGE CONTENTS

Please take an inventory of the package contents to ensure you have all the items listed below. If anything is missing or damaged, please contact Monoprice Customer Service for a replacement. Note that the 33049 version is a 2-pack version of 33048, so will contain twice as many of each item listed here.

1x Door/Window Sensor

1x Magnet

4x Screws

1x Adhesive Tape for Sensor

1x Adhesive Tape for Magnet

2x AAA Batteries

1x User's Manual

APPLICATIONS

Attach the device on windows, doors, gates, garage doors, drawers, mailboxes, and even your refrigerator to be the first to know the statuses of your entryways.



WINDOW



DOOR



GATE



GARAGE DOOR



DRAWER



MAIL BOX

PRODUCT OVERVIEW

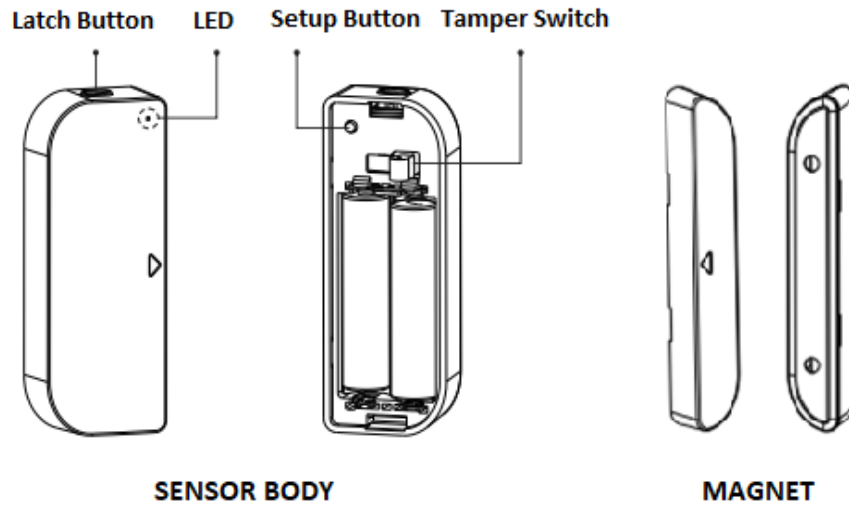

PHYSICAL INSTALLATION

1. Determine the mounting location. Note that the arrow on the magnet should be situated next to the arrow on the sensor with no more than a 0.4" (10mm) gap between the sensor and the magnet. Use a pencil to mark the locations. Ensure that the surfaces inside the marked locations are clean and free of dust and finger oils. The sensor should be placed indoors and away from water and other extreme weather conditions.

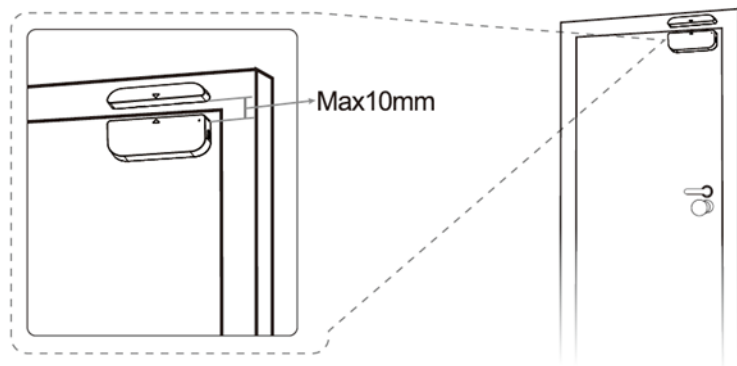
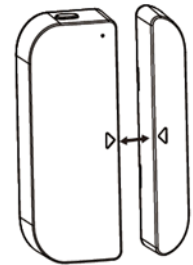

- Using a small flat-head screwdriver, remove the cover from the magnet, as shown in the image to the right.

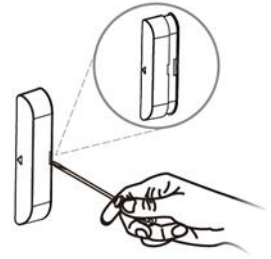

- If you will be mounting the magnet with screws, use two of the provided screws to secure the magnet back to the wall at the desired location previously marked. Otherwise, peel the protective film from one side of one of the included adhesive tape pieces and attach it to the back of the magnet back plate, then remove the other protective film and secure the magnet back plate to the wall at your desired location.

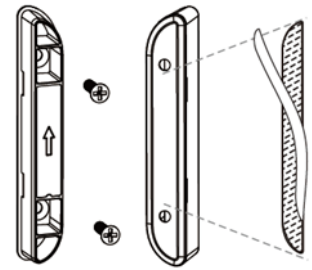

- Reinstall the cover on the magnet body.
- Press the latch button on the sensor and remove the sensor back plate from the main sensor body.

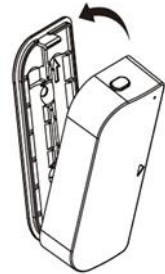

- If you will be mounting the sensor with screws, use two of the supplied screws to secure the sensor back plate to the wall, window, window frame, door, or door frame at the marked location. Alternatively, peel the protective film from one side of one of the included adhesive tape pieces and attach it to the back of the sensor back plate, then remove the other protective film and secure the sensor back plate and tape at your desired location.

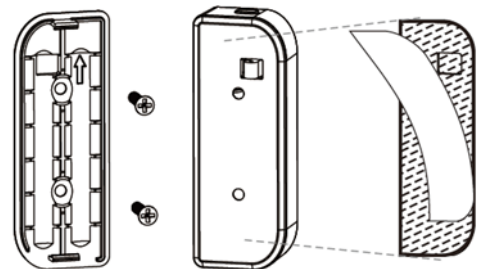

- Insert the two included AAA batteries into the battery compartment on the main sensor body, taking care to match the polarity, then reinstall the main sensor body onto the sensor back plate.

APP INSTALLATION AND LOGIN

1. Download and install the free **STITCH by Monoprice** app from Google Play™ or the App Store. Scan one of the two QR codes below to go directly to the appropriate app store.



2. Once it has been installed, launch the app.
3. If you have already used the STITCH app, tap the **Login** button, then enter your STITCH account information. If you have not installed and used the STITCH app before, proceed to app registration. You can register using your phone number or by using your email address. Follow the on-screen app instructions for more details.

Note that the password must contain 6-20 characters and must include at least one number.

A screenshot of the application's login interface. At the top, there is a teal header bar with a white back arrow and the text 'Login'. Below this, there are three input fields: 'Region' with a dropdown menu currently showing 'USA +1 >', 'Mobile Number/E-mail', and 'Password' with an eye icon to toggle visibility. A large, grey 'Login' button is positioned below the input fields. At the bottom of the screen, there are two links: 'Sign in with SMS' on the left and 'Forgot Password' on the right.

ADD A DEVICE

Smart Inclusion Installation

Smart Inclusion is the default mode for installing your device. It uses your wireless network to communicate between your smartphone and the smart device. If you do not have a Wi-Fi® network or do not wish to include the sensor in your network, see the *AP Mode* Installation section.

1. Tap + on the **Add Devices** screen to add a new device.

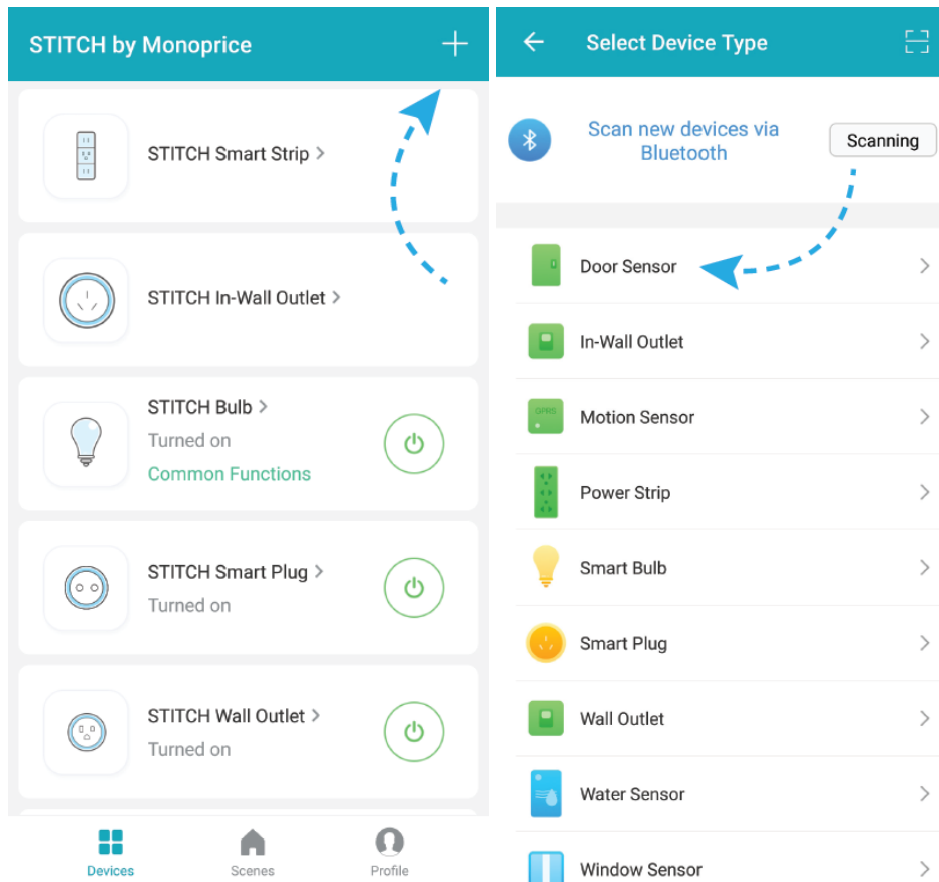

2. Scroll through the list and select **Door Sensor** or **Window Sensor** to add your new device to the STITCH app.

- The LED indicator should be flashing red rapidly, indicating that it is ready to be paired with your network. Tap **Confirm** on the app to continue, input the password to your wireless network, then tap **Confirm** again.

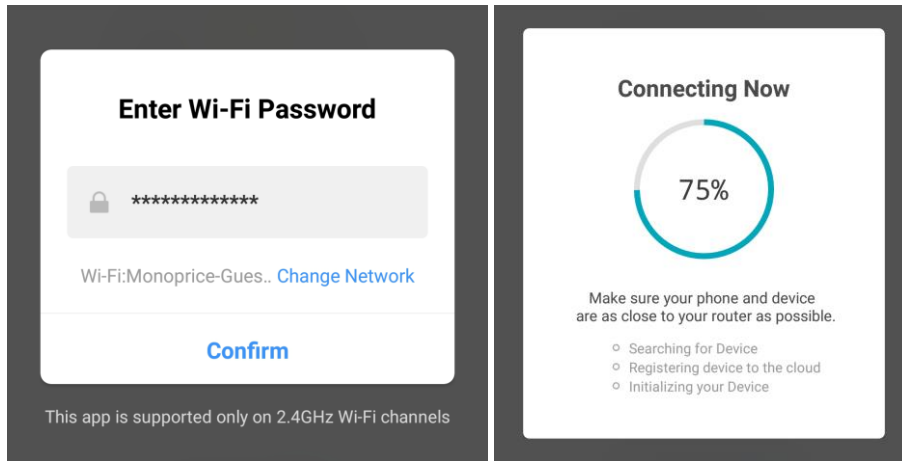

- The app will start connecting to the device. Tap **Done** once it is completed.

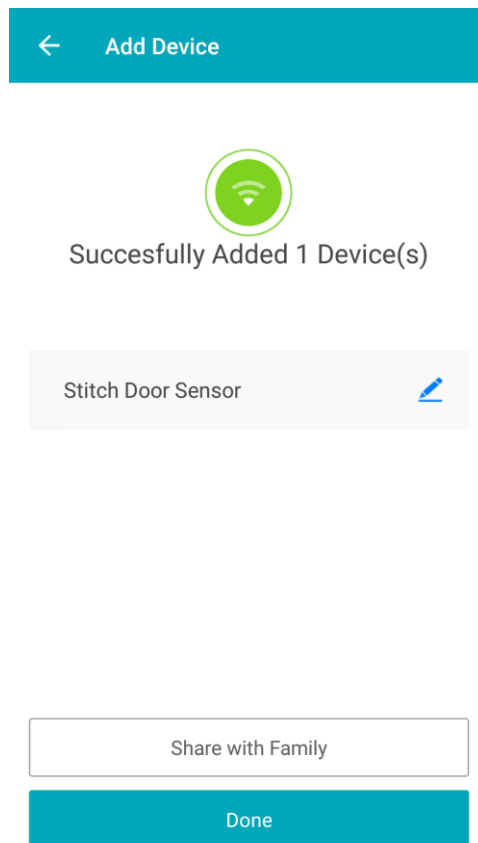

5. If the LED is not flashing red rapidly, open the cover and hold the **Setup** button for 5 seconds. The LED will flash red rapidly, indicating the device has been successfully reset.

AP Mode Installation

AP mode differs from Smart Inclusion mode in that it does not use your Wi-Fi® network to manage the communications between your smartphone and the device. Instead, it connects your phone's Wi-Fi directly to the device's built-in hotspot network.

1. Launch the **STITCH by Monoprice** app.
2. Tap **+** on the **Add Devices** screen to add a new device.

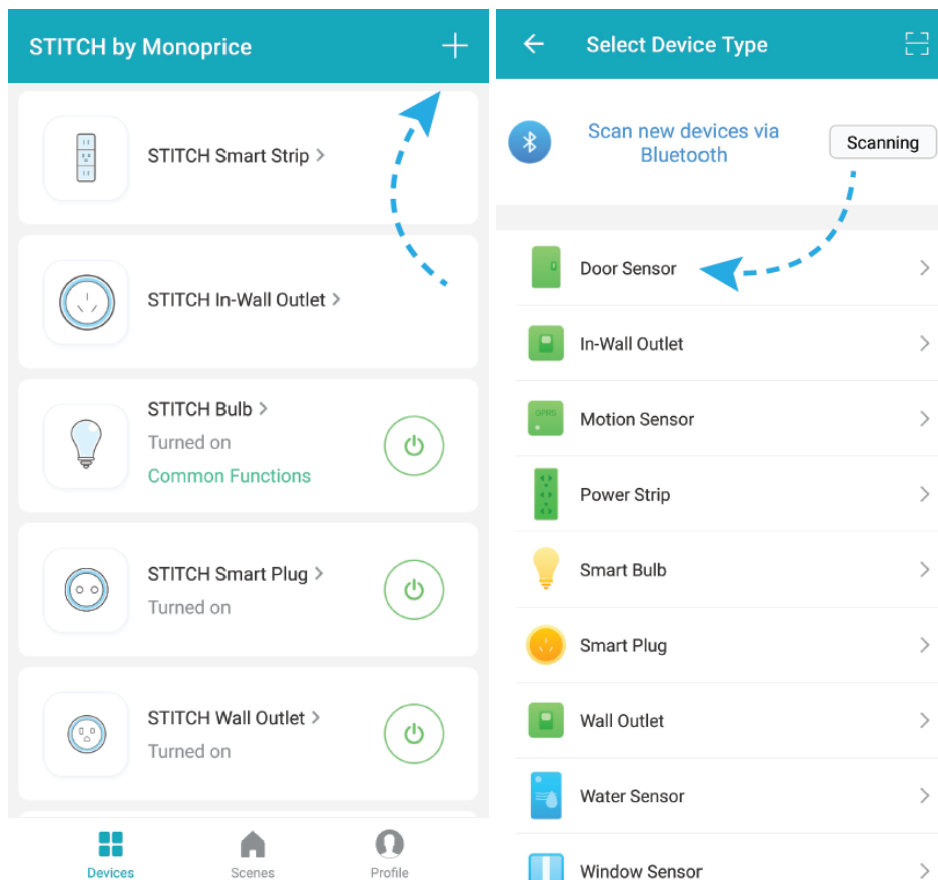

3. Scroll through the list and select **Door Sensor** or **Window Sensor** to add your new device to the STITCH app.

4. Tap **AP Mode** at the top right.

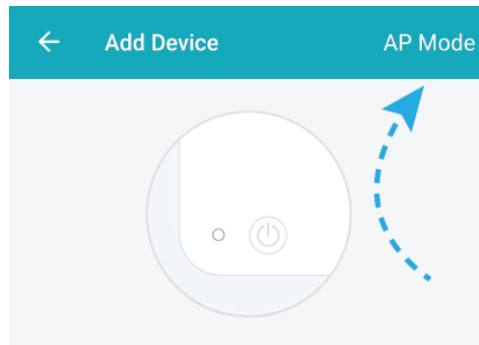

**Power on the device and confirm
that indicator light rapidly blinks**

[How to make indicator rapidly blink](#)

Confirm indicator rapidly blink

5. The LED should be slowly blinking, indicating that it is ready to be added in AP mode. If it does begin blinking slowly, tap **Confirm** on the app to continue, input the password to your wireless network, then tap **Confirm** again.

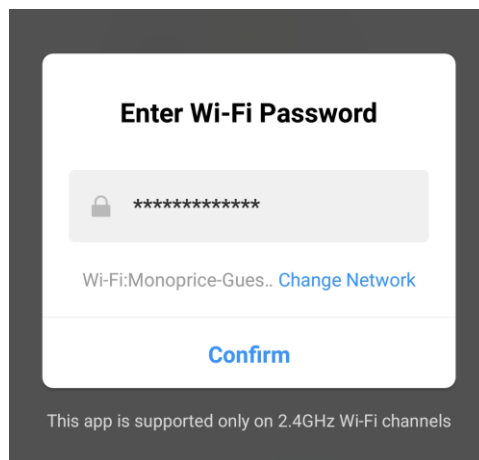

6. In the wireless settings on your phone, select the **Stitch-XXXX** entry, then tap **Connect Now** to continue. The app will begin connecting to the device.

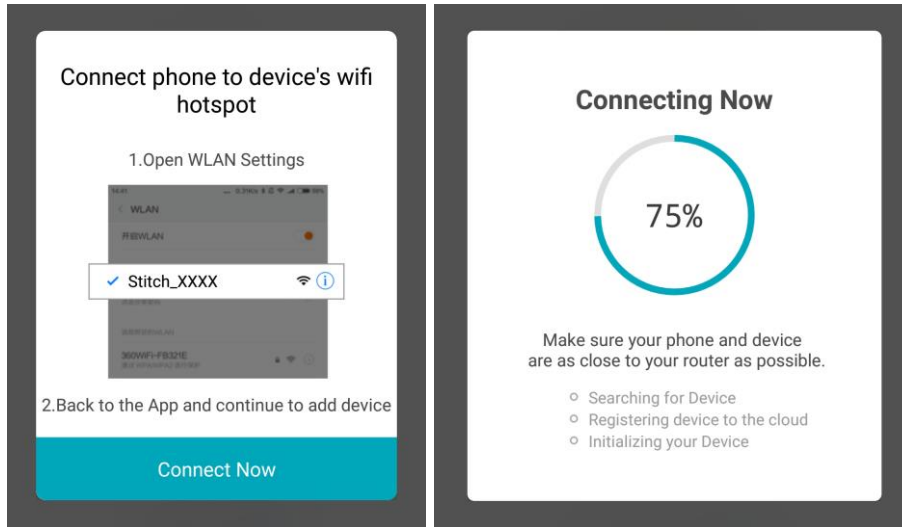

APP FEATURES

- Check closed and open statuses
- Check battery levels
- Review event history and logs
- Set device notifications
- Tamper alarm detection

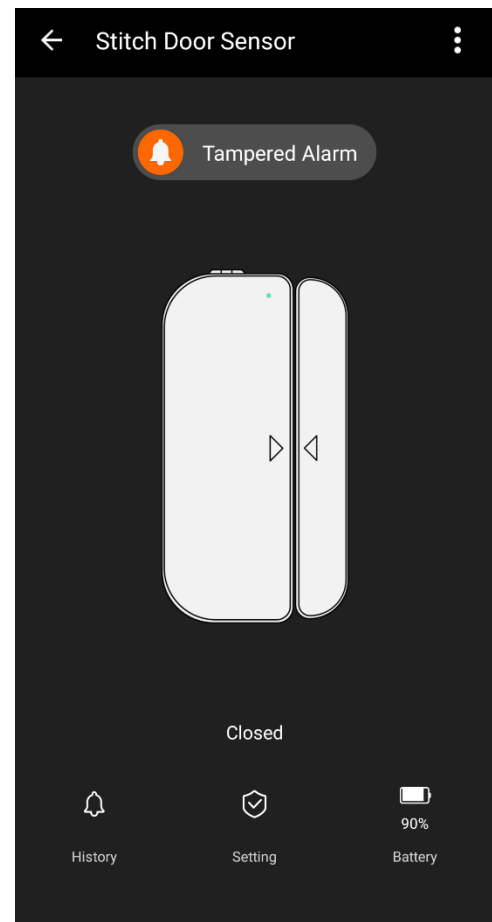

TECHNICAL SUPPORT

Monoprice is pleased to provide free, live, online technical support to assist you with any questions you may have about installation, setup, troubleshooting, or product recommendations. If you ever need assistance with your new product, please come online to talk to one of our friendly and knowledgeable Tech Support Associates. Technical support is available through the online chat button on our website www.monoprice.com during regular business hours, 7 days a week. You can also get assistance through email by sending a message to tech@monoprice.com

SPECIFICATIONS

Radio Frequency	2.4 ~ 2.484 GHz
Supported Network Protocols	IEEE802.11 b/g/n
Power Source	2x AAA batteries
Transmitting Power	802.11b: 20dBm \pm 2dBm @ 1Mbps 802.11g: 14dBm \pm 2dBm @ 54Mbps 802.11n: 14dBm \pm 2dBm @ MCS7_HT20
Receiving Sensitivity	802.11b: -91dBm @ 11Mbps 8% PER 802.11g: -75dBm @ 54Mbps 10% PER 802.11n: -72dBm @ MCS7_HT20 10% PER
Operating Temperature	+14 ~ +104°F (-10 ~ +40°C)
Storage Temperature	-40 ~ +158°F (-40 ~ +70°C)
Storage Humidity	8 ~ 80% RH, non-condensing
Sensor Dimensions	3.0" x 1.1" x 0.7" (75 x 28 x 18 mm)
Magnet Dimensions	3.0" x 0.5" x 0.7" (75 x 12 x 18 mm)

REGULATORY COMPLIANCE

Notice for FCC



Modifying the equipment without Monoprice's authorization may result in the equipment no longer complying with FCC requirements for Class A digital devices. In that event, your right to use the equipment may be limited by FCC regulations, and you may be required to correct any interference to radio or television communications at your own expense.

This equipment has been tested and found to comply with the limits for a Class A digital device, pursuant to Part 15 of the FCC Rules. These limits are designed to provide reasonable protection against harmful interference in a commercial installation. This equipment generates, uses and can radiate radio frequency energy and, if not installed and used in accordance with the instructions, may cause harmful interference to radio communications. Operation of this equipment in a residential area is likely to cause harmful interference, in which case the user will be required to correct the interference at his own expense.

RF Exposure Statement for FCC

Caution 

This equipment complies with radiation exposure limits set forth for an uncontrolled environment. End users must follow the specific operating instructions for satisfying RF exposure compliance. This transmitter must be at least 20 cm from the user and must not be collocated or operated in conjunction with any other antenna or transmitter.

Notice for Industry Canada

This Class A digital apparatus complies with Canadian ICES-003.

Cet appareil numérique de la classe A est conforme à la norme NMB-003 du Canada.

Radio Notice for Industry Canada

Caution

This IC RSS-210 radio device operates on a non-interference basis with other devices operating at this frequency. Any changes or modification to said product not expressly approved by Monoprice, including the use of non-approved antennas, could void the user's authority to operate this device.

This device complies with IC RSS-210. Operation is subject to the following two conditions: (1) this device may not cause harmful interference, and (2) this device must accept any interference received, including interference that may cause undesired operation.

RF Exposure Statement for Industry Canada

Caution

This equipment complies with radiation exposure limits set forth for an uncontrolled environment. End users must follow the specific operating instructions for satisfying RF exposure compliance. This transmitter must be at least 20 cm from the user and must not be collocated or operated in conjunction with any other antenna or transmitter.

Android™ and Google Play™ are trademarks of Google LLC.

Cisco® and IOS® are registered trademarks or trademarks of Cisco Systems, Inc. and/or its affiliates in the United States and certain other countries.

Wi-Fi® is a registered trademark of Wi-Fi Alliance.



TECHNOLOGY AT PRICES THAT MAKE SENSE

www.monoprice.com

Need Help? We're here for you!

Contact us: www.monoprice.com/contactus

Product pictures are for reference only.

Specifications described herein are subject to change without prior notification.

All trademarks are the sole property of their respective companies.

Stitch is a Sub-Brand for Smart Home of Monoprice.

Copyright © 2018 Monoprice, Inc. All rights reserved.